

Flash LED Driver IC

High Efficiency Synchronous Boost Converter with 1.8A Flash LED Drivers



AS6532

● General Description

The AS6532 is a 3MHz fixed frequency synchronous boost converter, optimized for maximum 0.90A/Ch, total 1.8A camera LED flash application and maximum 800mA movie mode applications using high-current white LEDs in all single cell Li-ion powered products. An adaptive regulation method ensures the current for each LED remains in regulation and maximizes efficiency.

Two simple logic control inputs (ENM and ENF) enable and disable flash and movie mode operation of the AS6532. Movie-mode and Flash-mode current levels are independently fixed by two separate resistors (RSETM and RSETF).

For flash mode, a default timer 800mS can be used either to terminate a flash event or as a safety flash timer. One or two LEDs can be connected to the AS6532; in the case of two LEDs the output current is matched between each diode.

The AS6532 integrate an intelligent flash current control mode: during flash current turn-on the input voltage falls below the flash mode supply monitor threshold, the flash current is stopped at the level that the current ramp had risen to, at the time of the flash mode supply monitor events.

The AS6532 contain a thermal management system to protect the device; a internal over-voltage protection (OVP) circuitry prevents damaged to the AS6532 from open LED or open circuit conditions; and a cycle-by-cycle current limit prevents damage to the AS6532. Built-in circuitry prevents excessive inrush current during start-up. The shutdown feature reduces quiescent current to less than 1.0 μ A.

The 3MHz switching frequency allow for the use of tiny, low profile (0.47 μ H or 1.0 μ H) inductors and 4.7 μ F ceramic capacitors. The device is available in 14-pin 2mmX3mm DFN package and is rated over the -40 $^{\circ}$ C to 85 $^{\circ}$ C.

● Features

- Input Voltage Range : 2.7V to 5.0V
- Up to 1MHz Movie/Torch PWM Dimming
- Power On Flash Mode Spurious Triggering Suppress
- Up to 3.0MHz Switching Frequency for Smaller Inductor Using
- Flash Current Soft-Start
- Optimize Flash Current During Low Battery
- Intelligent Flash Current Control
- High Efficiency PWM Boost Converter
- Up to 97% Efficiency with Small Inductor
- Integrated Soft-Start Eliminates Inrush Current
- Under Voltage Lock-Out
- Over-Temperature Protection
- Over Voltage (Open LED) Protection
- LED Short Circuit Protection
- Lower LED Short Circuit Current: 1.0mA
- 800mS Flash Timer Control
- Cycle by Cycle Current Limit
- Separate Hardware Flash and Movie Enable
- Drives up to 1.8A Regulated Output Current (0.90A per Channel)
- Independently Set Flash/Movie Currents
 - Flash Mode Current Up to 0.90A/Ch
 - Movie Mode Current Up to 0.40A/Ch
- Two Resistors Set Flash and Movie Current Independently
- Small Solution Size
- Less than 1 μ A Shutdown Current
- RoHS and Green Compliant
- 14- pin, 2mm X 3mm DFN Packages
- -40 $^{\circ}$ C to +85 $^{\circ}$ C Temperature Range

● Applications

- Camera Flashes and Movies
- Cell Phones or Smart Phones
- PDAs and Digital Camera
- White LED Biasing
- Mobil Handsets
- Tablet PCs and Laptops/Netbooks
- Camcorder Video Light (Movie Light)

■ **Ordering Information**

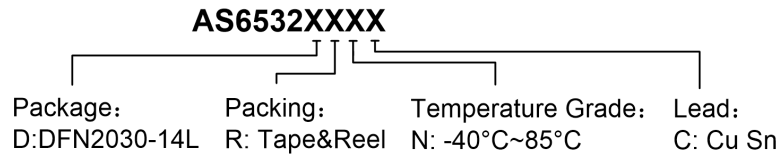

Part Number	Driver Capability	Package Type	Package Qty	Temperature	Eco Plan	Lead
AS6532DRNC	1.8A	DFN2030-14L	7-in reel 3000pcs/reel	-40~85°C	Green	Cu Sn

■ **Marking Information**

DFN2030-14L

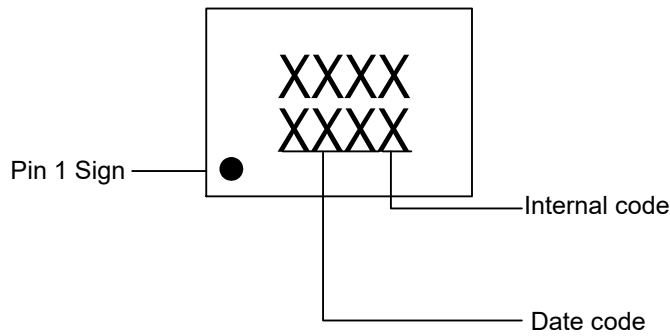

■ **Typical Application Circuit**

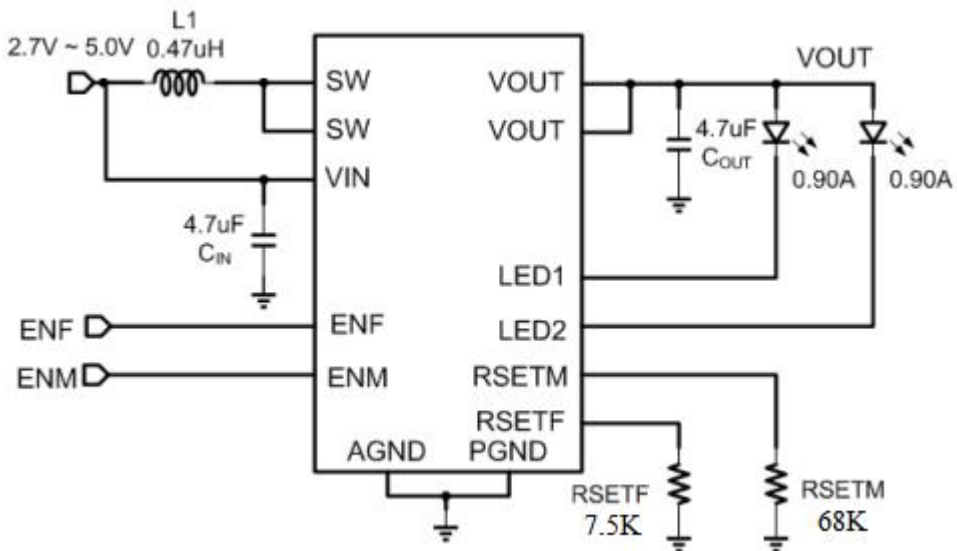
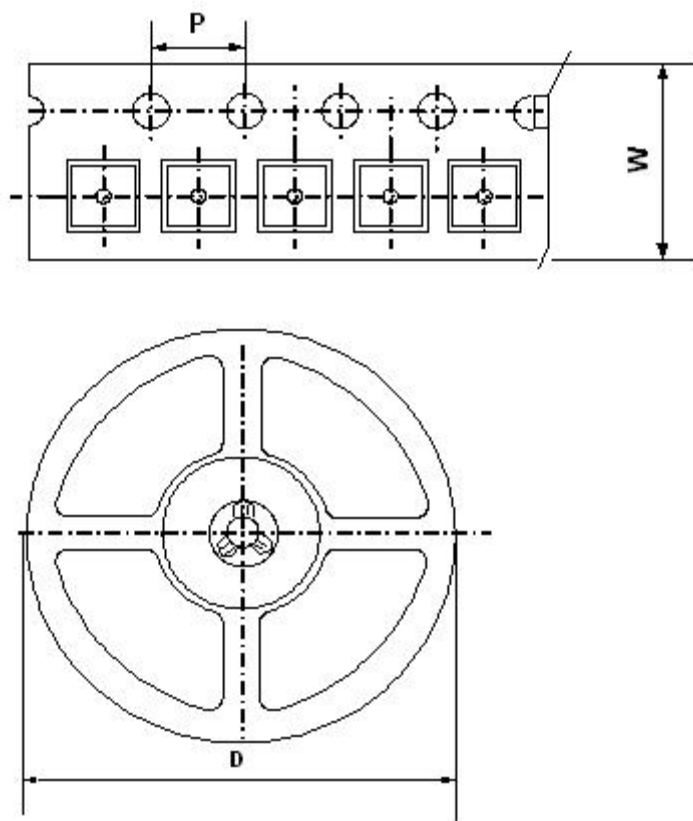

Figure 1, Movier/Torch Mode Typical Application Circuit of AS6532

■ Packing Information



Package Type	Carrier Width(W)	Pitch(P)	Reel Size(D)	Packing Minimum
DFN2030-14L	8.0±0.1 mm	4.0±0.1 mm	180±1 mm	3000pcs

Note: Carrier Tape Dimension, Reel Size and Packing Minimum