

Magnetic Sensor ICs

Omnipolar Detection High Performance Low Power 3D Hall-Effect Sensor IC



AS1190OD

● General Description

Using low power CMOS process, the AS1190OD is designed for low power, high performance omnipolar detection 3D hall-effect application. The 3D hall IC integrated an on-chip hall voltage generator for magnetic sensing, a comparator that amplifies the hall voltage, a Chopper amplifier, a Schmitt trigger to provide switching hysteresis for noise rejection, and a complementary output.

The total power consumption of AS1190OD is typically less than 2.0uA at 2.8V power supply. AS1190OD is designed to respond to alternating North and South poles. When the magnetic flux density (B) is larger than operate point (B_{OP}), the output will be turned on (low), the output is held until the magnetic flux density (B) is lower than release point (B_{RP}), then turn off (high).

The device is available in SOT23-3L and SIP-3L Package and is rated over the -40°C to 125°C. The all packages are RoHS and Green compliant.

● Features

- 3D (X, Y, Z) Magnetic Flux Switch
- Omnipolar Operation, easy to use as output
- Input Voltage Range : 2.2V to 5.5V
- Micro-power consumption ideal for battery power applications: 2.0uA/2.8V
- Very high sensitivity hall sensor
- Low Power CMOS process technology
- Chopper stabilization amplifier stage
- High Magnetic Sensitivity
- Good RF noise immunity
- Open-Drain Output
- Small Solution Size
- RoHS & Green Compliant
- SOT23-3L & SIP-3L Packages
- -40°C to +85 °C Temperature Range

● Applications

- Smart Meter
- Cover switch
- Contact-less switch
- Air Cylinder, Antitheft window, Digital door lock
- Water Purifier, Humidifier Bidet
- Water Meter, Gas Meter, Wattmeter etc
- Washing Machine, Rice Cooker, Refrigerator, Electronic Dictionary, Digital Camera etc

■ Ordering Information

AS1190ODXXX



Part Number		B _{OP} (Gauss)	B _{RP} (Gauss)	Package Type	Package Qty	Temperature	Eco Plan
AS1190ODSTRN	X/Y	±22	±15	SOT23-3L	7-in reel 3000pcs/reel	-40~85°C	Green
	Z	±10	±7				
AS1190ODMBN	X/Y	±22	±15	SIP-3L	1K/Package	-40~85°C	RoHS
	Z	±10	±7				
AS1190ODSTRY	X/Y	±22	±15	SOT23-3L	7-in reel 3000pcs/reel	-40~125°C	Green
	Z	±10	±7				
AS1190ODMBY	X/Y	±22	±15	SIP-3L	1K/Package	-40~125°C	RoHS
	Z	±10	±7				

■ **Marking & Pin Assignment**

SOT23-3L:

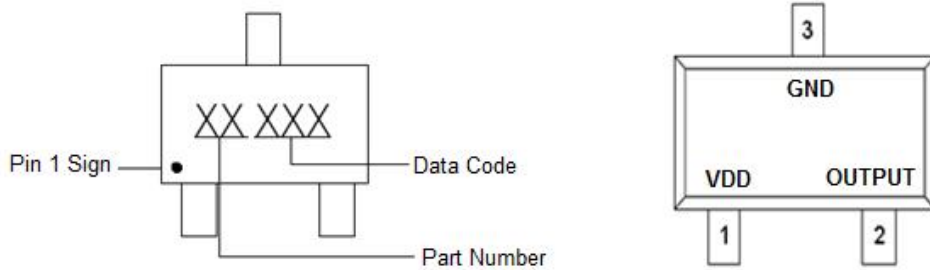

Pin Name	Pin No.	I/O	Pin Function
	SOT23-3L		
VDD	1	P	Input Power Supply
GND	3	P	Ground
OUTPUT	2	O	Output Pin

SIP-3L:

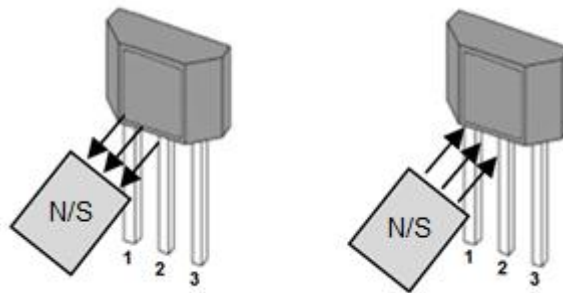

Pin Name	Pin No.	I/O	Pin Function
	SIP-3L		
VCC	1	P	Input Power Supply
GND	2	P	Ground
OUTPUT	3	O	Output Pin.

■ **Typical Application Circuit**

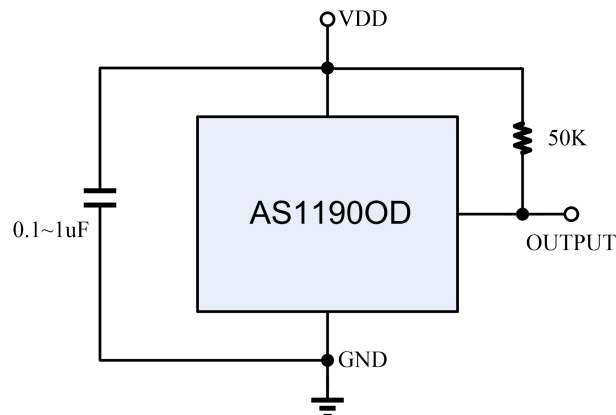
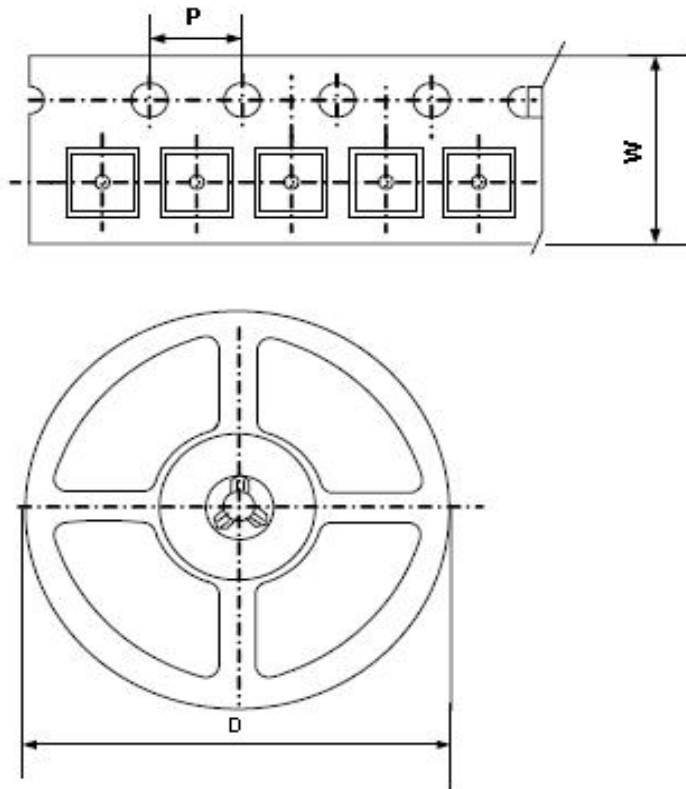

Figure 1, Typical Application Circuit of AS1190OD

■ **Packing Information**

SOT23-3L:



Package Type	Carrier Width(W)	Pitch(P)	Reel Size(D)	Packing Minimum
SOT23-3L	8.0±0.1 mm	4.0±0.1 mm	180±1 mm	3000pcs

Note: Carrier Tape Dimension, Reel Size and Packing Minimum

■ **Packing Information**

SIP-3L

1. Packing type: Bulk
2. Packing minimum: 1000pcs