

Magnetic Sensor IC

North Unipolar Detection High Performance Low Power Hall-Effect Sensor IC



AS1911

● General Description

Using low power CMOS process, the AS1911 is designed for low power, high performance unipolar detection hall-effect application, such as cover switch, contactless switch, solid state switch and lid close sensor etc battery operation. The hall IC integrated an on-chip hall voltage generator for magnetic sensing, a comparator that amplifiers the hall voltage, a Chopper amplifier, a Schmitt trigger to provide switching hysteresis for noise rejection, and a complementary output.

The total power consumption of AS1911 is typically less than 2.0uA at 1.8V power supply. AS1911 is designed to respond to alternating North pole. When the magnetic flux density (B) is larger than operate point (B_{OPN}), the output will be turned on (low), the output is held until the magnetic flux density (B) is lower than release point (B_{RPN}), then turn off (high).

The device is available in SOT553, SIP-3L, SOT23-3L and TSOT23-3L Package and is rated over the -40°C to 85°C. The package is RoHS and Green compliant.

● Features

- Input Voltage Range : 1.65V to 5.0V
- Micro-power consumption ideal for battery power applications
- Uniplar Operation, easy to use as output
- Very high sensitivity hall sensor
- Low Power CMOS process technology
- Chopper stabilization amplifier stage
- Magnetic Sensitivity (typical)
 $B_{OPN}=-40\text{Gauss}$, $B_{RPN}=-25\text{Gauss}$
- Good RF noise immunity
- No need pull-up resistor
- Small Solution Size
- RoHS & Green Compliant
- SOT553, SIP-3L, SOT23-3L and TSOT23-3L Package
- -40°C to +85 °C Temperature Range

● Applications

- Cover switch in clam-shell cellular phones
- Cover switch in Notebook, PC/PAD
- Contact-less switch in consumer products
- Solid State Switch
- Handheld Wireless Handset Awake Switch
- Lid close sensor for battery-powered devise
- Magnet proximity sensor for reed switch replacement in low duty cycle applications
- DV, DSC, and White Goods

■ Ordering Information

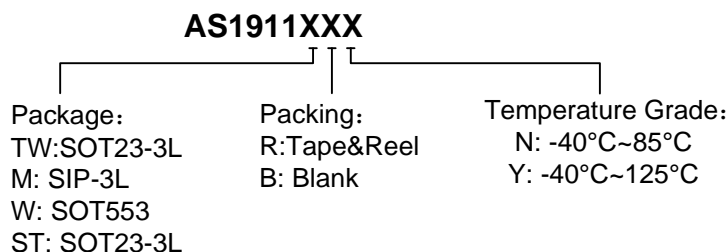

Part Number	B_{OPN} (Gauss)	B_{RPN} Gauss)	Package Type	Package Qty	Temperature	Eco Plan	Lead
AS1911TWRN	-40	-25	TSOT23-3L	7-in reel 3000pcs/reel	-40~85°C	Green	Cu
AS1911MBY	-40	-25	SIP-3L	1000pcs/Package	-40~125°C	Rohs	Cu
AS1911WRN	-40	-25	SOT553	7-in reel 3000pcs/reel	-40~85°C	Green	Cu
AS1911STRN	-40	-25	SOT23-3L	7-in reel 3000pcs/reel	-40~85°C	Green	Cu

■ **Marking & Pin Assignment**

SOT553:

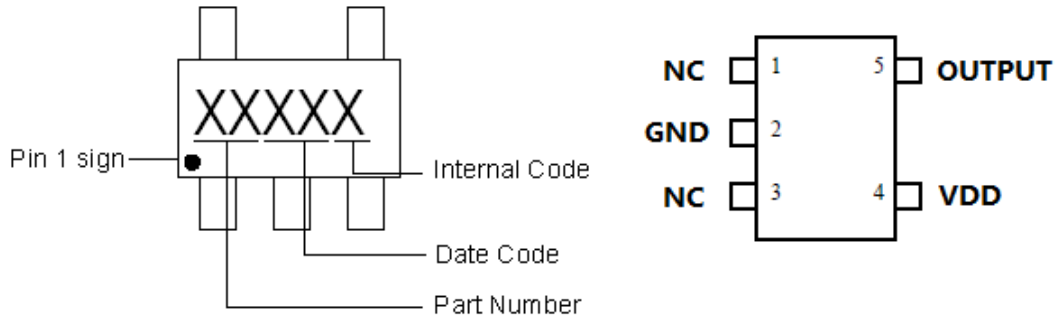

Pin Name	Pin No.	I/O	Pin Function
	SOT553		
VDD	4	P	Input Power Supply
GND	2	P	Ground
NC	1, 3	-	Not Connected
OUTPUT	5	O	Output Pin

TSOT23-3L/SOT23-3L

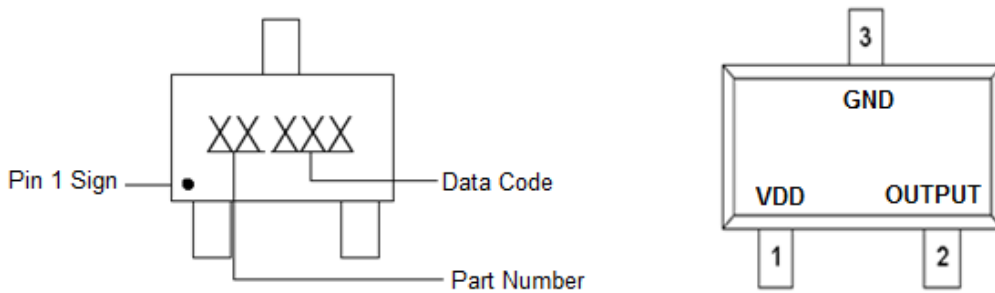

Pin Name	Pin No.	I/O	Pin Function
	TSOT23-3L/SOT23-3L		
VDD	1	P	Input Power Supply
GND	3	P	Ground
OUTPUT	2	O	Output Pin

SIP-3L:

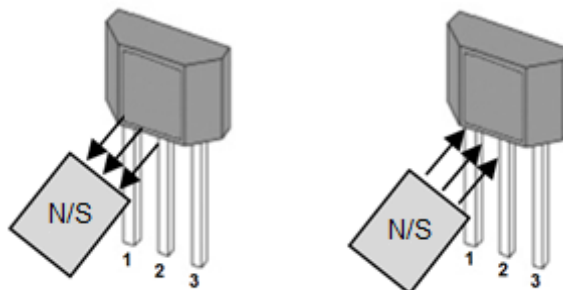

Pin Name	Pin No.	I/O	Pin Function
	SIP-3L		
VDD	1	P	Input Power Supply
GND	2	P	Ground
OUTPUT	3	O	Output Pin.

■ **Packing Information**

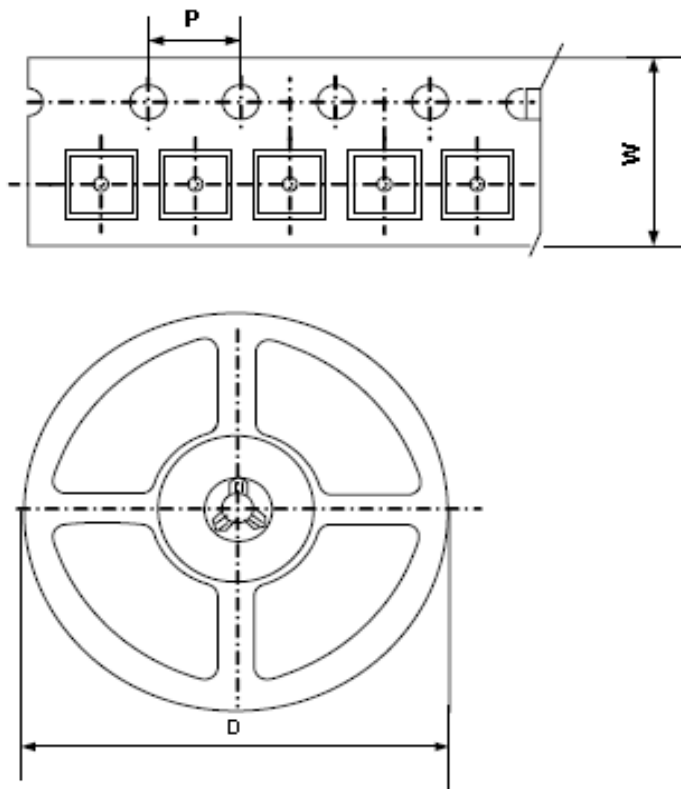

Package Type	Carrier Width(W)	Pitch(P)	Reel Size(D)	Packing Minimum
SOT553	8.0±0.1 mm	4.0±0.1 mm	180±1 mm	3000pcs
TSOT23-3L	8.0±0.1 mm	4.0±0.1 mm	180±1 mm	3000pcs
SOT23-3L	8.0±0.1 mm	4.0±0.1 mm	180±1 mm	3000pcs

Note: Carrier Tape Dimension, Reel Size and Packing Minimum

■ **Packing Information**

SIP-3L:

- 1, Packing type: Bulk
- 2, Packing minimum: 1000pcs